

MOVIX

item no. description

spare parts floor scrubber Movix

211116	Freshwater tank, black
211117	Wastewater tank, black
211118	Filter for freshwater tank
211119	Filter freshwater system
211120	HEPA-filter wastewater tank
211122	Mainboard
211125	Vacuum suction motor 150W
211130	Fresh water level senso
211134	Fresh water pipe
211135	On/Off button
211136	Spray On/Off button
211137	Operating switch
211138	Joint lock
211139	Joint
211140	Chassis connectors
211141	Locking element joint

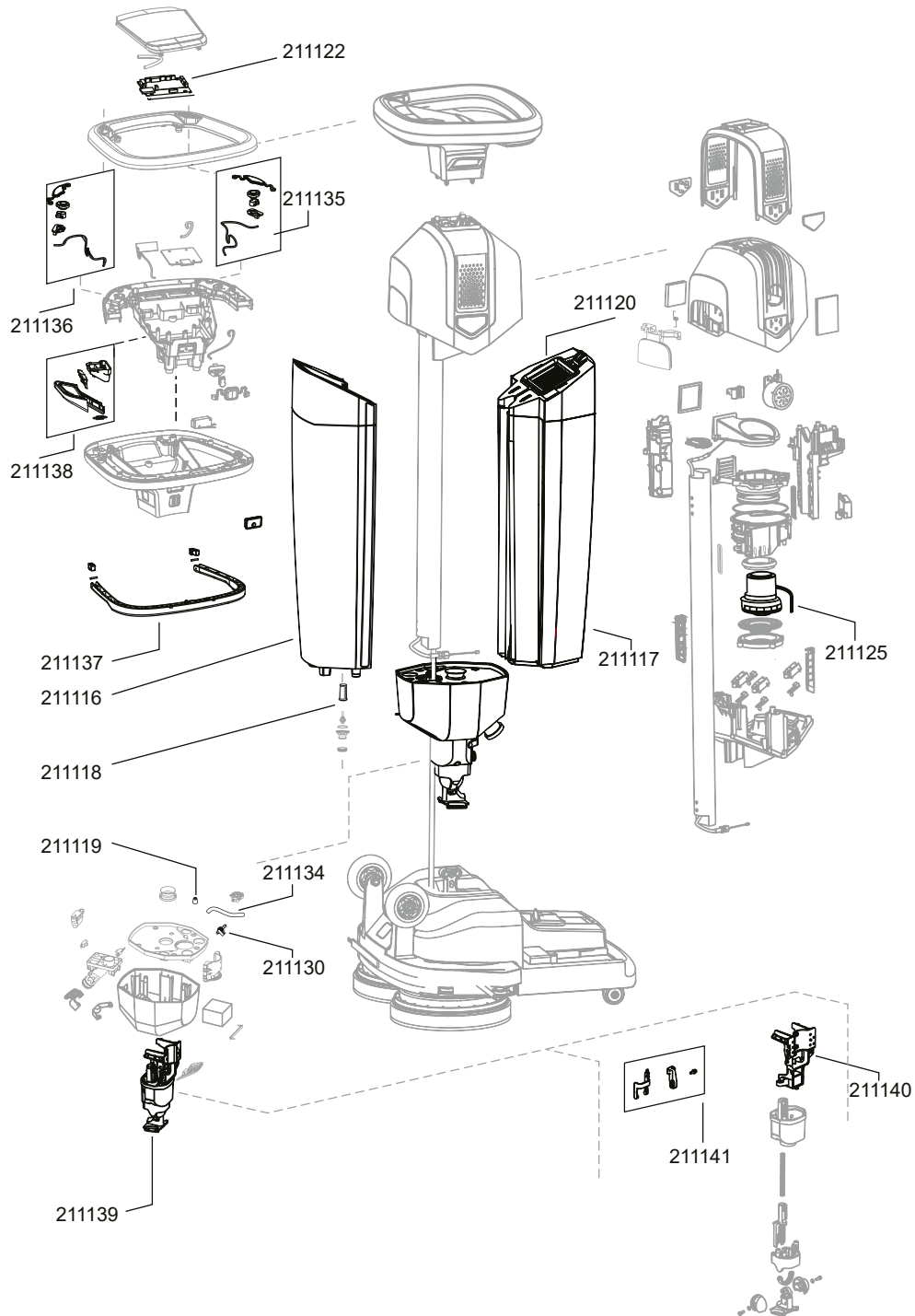

MOVIX

item no. description

spare parts floor scrubber Movix

210132	Cable for internal charger EU
211102	Power supply unit, dual charger, 8 A
211103	Station double charger
211104	Brush, red, 200 mm, (PU = 2 pcs)
211111	Squeegee lip red 1 pair
211114	Squeegee bar
211115	Suction hose squeegee bar
211123	Electronics Battery management
211124	LED light bar
211126	Brush motor, left
211127	Brush motor, right
211110	Flange brush holder (incl. 211145)
211128	Magnet valve, 12V
211131	Transport wheel, 1 pair
211132	Deflector roll, (PU = 4pcs)
211133	Wheel suction bar, (PU = 4 pcs)
211142	Suction bar raiser
211143	Switching element Brush switch-off
211144	Unlocking transport position
211145	Set of hexagon machine screws

accessories floor scrubber Movix

211104	Brush, red, 200 mm, (PU = 2 pcs)
211105	Brush, black, 200 mm, (PU = 2 pcs)
211106	Melamine pad, 200 mm, (PU = 4 pcs)
211107	Pad holder, 200mm (PU = 2 pcs)
211108	Pad white, 200mm (PU = 4 pcs)
211109	Pad red, 200mm (PU = 4 pcs)
211110	Pad black, 200mm (PU = 4 pcs)
211112	Squeegee lip blue oil resistant 1 pair
211113	Splash guard brush head (PU = 2 pcs)
211121	Battery 24V/13Ah

