

# N51/1 KPS

item no. description

## spare parts pump vacuum N 51/1 KPS

102046	sealing tape broad
106016	switch, electrical
109117	vacuum motor, 1300 Watt
109011	key button
109012	spring for key button
109013	cover
109014	socket board incl. cover
109015	socket
109016	socket cover
109018	switch housing
109022	strain relief
109024	airflow
109030	motor bearing top
109031	motor bearing bottom
109033	airflow housing, bottom
109035	screw K5, 5x30
109041	opening lid
109046	exit air housing set
109048	filter sponge, exit air
109052	seal, floater
109054	floater
110020	wire set
110057	exit air housing
110070	base plate
113248	power cord, 10m, with PRCD-safety switch
110073	filter sponge, exit air
110074	distance cage
110075	vacuum head complete
113259	PRCD-safety switch
110082	floater housing

# N51/1KPS

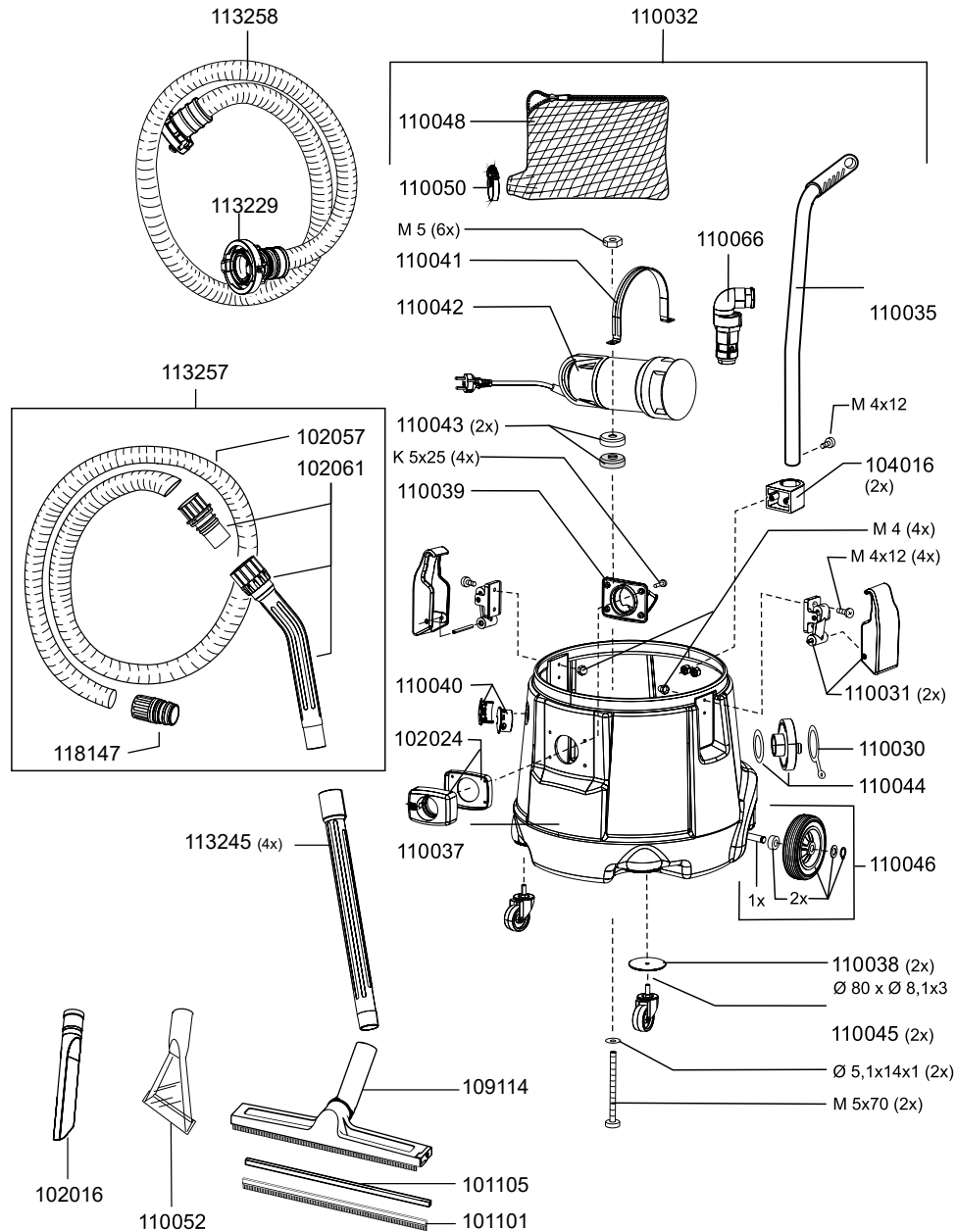

item no. description

## spare parts pump vacuum N 51/1 KPS

102016	crevice nozzle, D38, 240mm
102024	inlet D38 complete
102061	handle with hose connector D38, antistatic
102062	hose connector for container, antistatic
104016	clamp for bracket
109114	wet floor nozzle, D38, 360mm, with parking hook
110030	gasket ring with cap
110031	latch
110032	container complete
110035	push rod
110037	container
110038	washer 80x8, 1x3
110039	inlet fitting
110040	cable gland, container
110041	pump attachment
110042	pump
110043	disc VA with seal
110044	C-coupling with threaded connection
110045	castor, D50
110046	wheel set
110048	filter net
113257	vacuum hose, D38, 7m
110050	reopening ties
110052	pond nozzle, D38, 90mm
113258	C-hose pump side, D38, 10m
110066	tube set for pump
113229	C-coupling connection
118157	hose connector for handle, antistatic
113245	vacuum tube, D38, plastic

## accessory pump vacuum N 51/1 KPS

101101	spare lip 360mm for 101106
101105	plastic rail 360mm for 101106, 111202
102057	vacuum hose per meter, D38
102124	wet floor nozzle, D38, 450mm, with parking hook